



**Operations and Maintenance Manual
for
PSP Series
Water Purification Systems
PSP-600
PSP-1000
PSP-1600
PSP-2700**

Rev. 0 / April 21, 2005

Compact Design, Self-Contained Water Processing Unit for Point-Of-Use or Point-Of-Entry Applications:

Easy to Install or Retrofit: Four water connections and 115VAC or 230VAC.

Easy to Maintain: Uses Industry Standard components - no more proprietary parts or sole-sourcing. All filters and components are on the front panel for easy access.

Single membrane can be changed in minutes, no need to remove membrane housings and fittings to change membrane.

Water conserving design features 50% recovery - produces 1 gallon of water while sending only 1 gallon to drain. Other RO systems may waste as much as 4 gallons to produce 1 gallon of purified water. Many municipalities charge for water coming in as well as sewage. Not only is that expensive but environmentally unsatisfactory, especially in drought-stricken areas.

Concentrate recirculation loop decreases membrane fouling by rapidly flushing the membrane at a high velocity, greatly increasing membrane life.

Time-delayed inlet solenoid valve operates for several seconds before pump activates, protecting the pump from dry starts and pump-destroying cavitation.

Low-voltage microprocessor-based control system with Auto Flush and Pump Protection. Flushes membrane after each use and protects pump from running dry, preventing premature pump failure.

These systems may be engineered for use with a single reservoir, multiple storage tanks or a bladder tank.

Liquid level controls and sediment filter are included.

* A water softener may be required in some hard water areas.

** Additional pre-treatment may be required for brackish water.

Specifications for Back-Washable Carbon Pre-Filter (Required):

Power Requirements	Single phase, 60 Hz., 115 VAC, .3 Amps
Safety System Interlock	Prevents RO system from operating when carbon filter is back washing
Dimensions	Tank sizes are available starting at 1 cu.ft.

Specifications for Water Softener (Optional):

Power Requirements	Single phase, 60 Hz., 115 VAC, .3 Amps
Safety System Interlock	Prevents RO system from operating when water softener is regenerating
Dimensions	Tank sizes are available starting at 32K grain capacity

Specifications for PSP-750 & PSP-1000 Water Purification Unit:

Number of Membranes	One 4.0" x 21" High Rejection (PSP-600) One 4.0" x 21" High Production (PSP-1000)
Type of Membrane	Low Pressure, Energy Saving TFC Membrane
Sediment Pre-Filter	20 in. 1 micron
Membrane Housing Material	Stainless Steel
Operating Pressure	110 psig max
Operating Design Temperature	40°F to 86°F (4.5°C to 30°C)
Membrane Rejection	greater than 98% average
RO System Recovery	50%
Feed flow (GPM)	1.0 GPM at 100 psi, 77 °F (PSP-600) 1.4 GPM at 100 psi, 77 °F (PSP-1000)
Concentrate Reject flow (GPM)	0.5 GPM at 100 psi, 77 °F (PSP-600) 0.7 GPM at 100 psi, 77 °F (PSP-1000)
Permeate Product flow (GPM)	0.5 GPM at 100 psi, 77 °F (PSP-600) 0.7 GPM at 100 psi, 77 °F (PSP-1000)
Production Rate, 100 psi, 1500ppm NaCl	750 GPD @ 77°F. (PSP-600) 1000 GPD @ 77°F. (PSP-1000)
System Inlet port	5/8" compression
Permeate Product port	1/2" compression
Concentrate Reject port	1/2" compression
RO (Reverse Osmosis) pump	Rotary Vane Procon
Motor	General Electric
Motor Horsepower	0.75 hp (1725 RPM) at 60 Hz
Power Requirements	Single phase, 60 Hz., 115 VAC, 10.4 Amps Single phase, 60 Hz., 230 VAC, 5.2 Amps
Dimensions	20 in. x 17 in. x 48 in.

Specifications for PSP-1600 Water Purification Unit:

Number of Membranes	One 4.0" x 40" High Rejection
Type of Membrane	Low Pressure, Energy Saving TFC Membrane
Sediment Pre-Filter	20 in. 1 micron
Membrane Housing Material	Stainless Steel
Operating Pressure	110 psig max
Operating Design Temperature	40°F to 86°F (4.5°C to 30°C)
Membrane Rejection	greater than 98% average
RO System Recovery	50%
Feed flow (GPM)	2.2 GPM at 100 psi, 77 °F
Concentrate Reject flow (GPM)	1.1 GPM at 100 psi, 77 °F
Permeate Product flow (GPM)	1.1 GPM at 100 psi, 77 °F
Production Rate, 100 psi, 1500ppm NaCl	1600 GPD @ 77°F.
System Inlet port	5/8" compression
Permeate Product port	1/2" compression
Concentrate Reject port	1/2" compression
RO (Reverse Osmosis) pump	Rotary Vane Procon
Motor	General Electric
Motor Horsepower	0.75 hp (1725 RPM) at 60 Hz
Power Requirements	Single phase, 60 Hz., 115 VAC, 10.4 Amps Single phase, 60 Hz., 230 VAC, 5.2 Amps
Dimensions	20 in. x 17 in. x 48 in.

Specifications for PSP-2700 Water Purification Unit:

Number of Membranes	One 4.0" x 40" High Production
Type of Membrane	Low Pressure, Energy Saving TFC Membrane
Sediment Pre-Filter	20 in. 1 micron
Membrane Housing Material	Stainless Steel
Operating Pressure	110 psig max
Operating Design Temperature	40°F to 86°F (4.5°C to 30°C)
Membrane Rejection	greater than 98% average
RO System Recovery	50%
Feed flow (GPM)	3.8 GPM at 100 psi, 77 °F
Concentrate Reject flow (GPM)	1.9 GPM at 100 psi, 77 °F
Permeate Product flow (GPM)	1.9 GPM at 100 psi, 77 °F
Production Rate, 100 psi, 1500ppm NaCl	2700 GPD @ 77°F.
System Inlet port	5/8" compression
Permeate Product port	1/2" compression
Concentrate Reject port	1/2" compression
RO (Reverse Osmosis) pump	Multi-Stage
Motor	Flint & Walling or Gould
Motor Horsepower	0.75 hp (1725 RPM) at 60 Hz
Power Requirements	Single phase, 60 Hz., 115 VAC, 10.4 Amps Single phase, 60 Hz., 230 VAC, 5.2 Amps
Dimensions	20 in. x 17 in. x 48 in.

Theory of Operation: Water Production System

The storage tank (11) is a non-pressurized tank of any size. When water is withdrawn from the tank to a point below the low-level float (or pressure switch) (12), the input solenoid (2) is activated by the Reverse Osmosis System Controller (27). When sufficient input pressure (as displayed on the input pressure gauge (4)) is sensed by the input pressure switch (5), the main pump (6) and motor (7) are energized. Water that has passed through the sediment filter (1) then flows through the low pressure manifold (3). The pump increases the input water pressure in the membrane (8) to a conservative 100 psi as displayed on the system pressure gauge (21).

The water is split by the membrane into two streams: a pure water stream (permeate) and a waste water stream (concentrate). The pure water stream passes through the product flow meter (10) and the TDS monitor (18) and then into the storage tank. (The TDS Meter indicates the purity of the product water going into the tank and aids in determining when the RO membrane may be failing.) The tank will fill until water reaches the high-level float (or pressure switch) (13). This will activate the flush cycle (covered later) and then shut the pump and motor down.

The concentrate stream is split into two streams in the high pressure manifold (20). One stream goes to drain through the capillary tube flow restrictor (22) and concentrate flow meter (23). The other stream goes through the pressure regulator (24). The pressure regulator is used to adjust the system operating pressure. The output of the pressure regulator is feed back into the input water supplying the pump.

The flush cycle, initiated by the high-level float (or pressure switch), opens the concentrate bypass solenoid (25). This allows the concentrated waste water (as well as any hardness or particulates that may have accumulated on the surface of the membrane) to be rapidly flushed down the drain. After 45 seconds, the pump and motor will spin down before the input solenoid is turned off, protecting the pump from a starvation / cavitation condition. For the next six minutes, the pure water flush pump (9) is activated, flooding the membrane with a pure-water bath until the fill cycle starts over again.

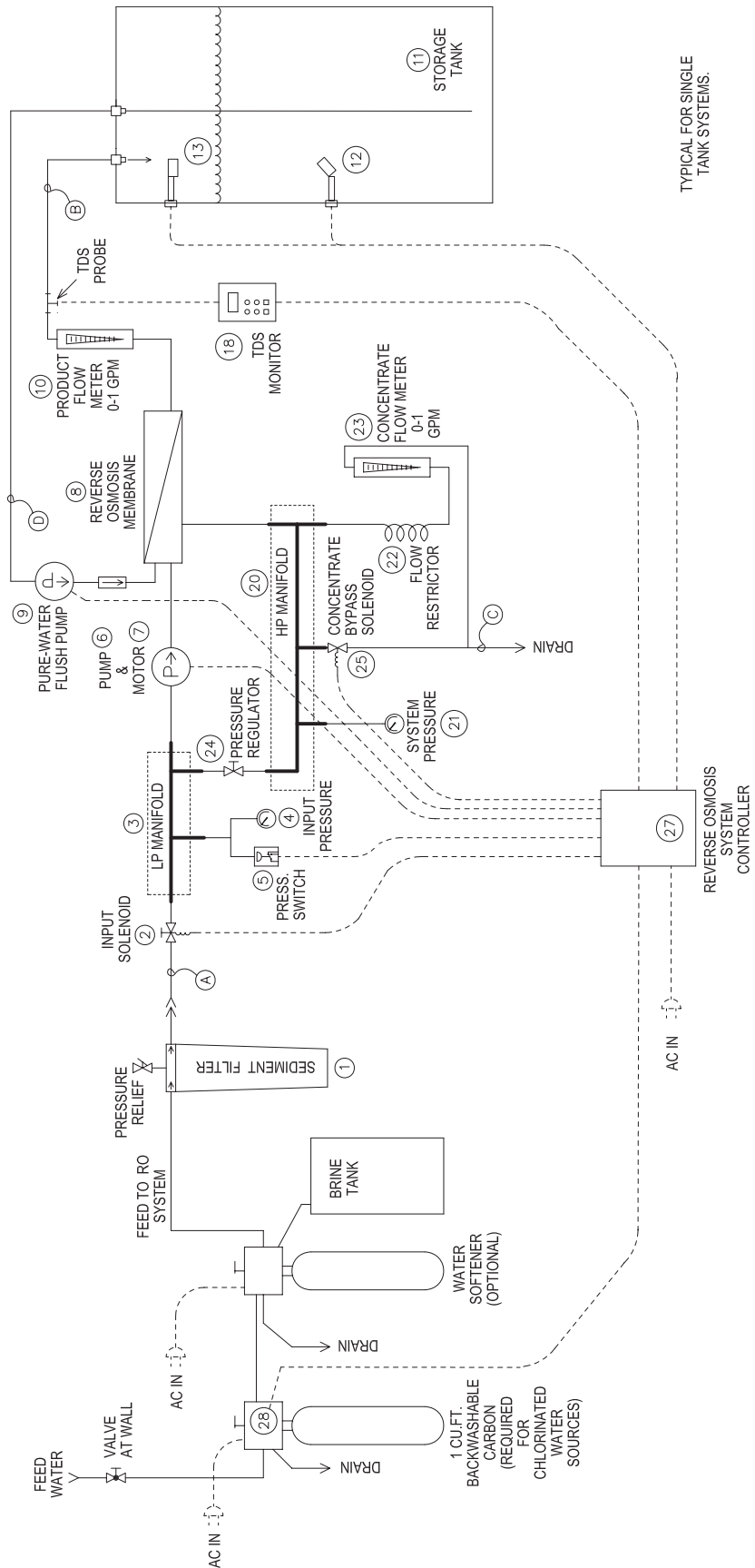

TYPICAL FOR SINGLE TANK SYSTEMS.

Schematic for All Systems Using One Open Tank

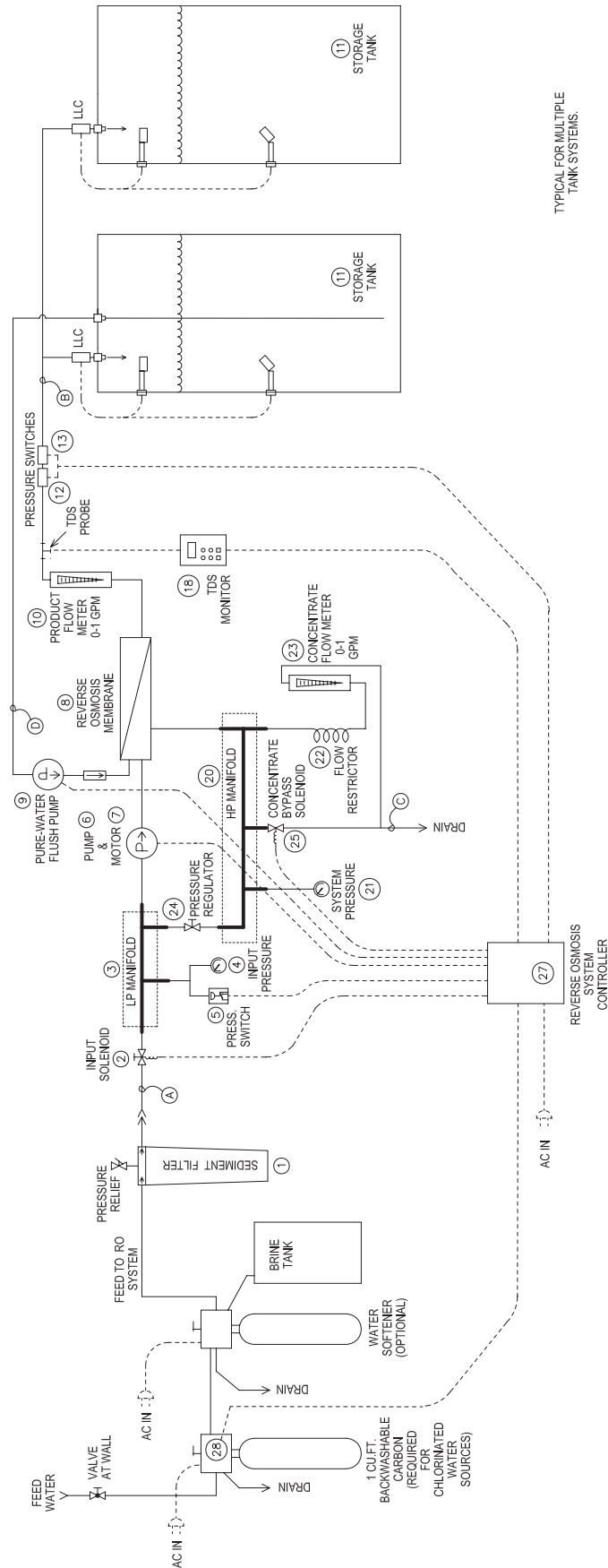

TYPICAL FOR MULTIPLE TANK SYSTEMS.

Schematic for All Systems Using Multiple Open Tanks

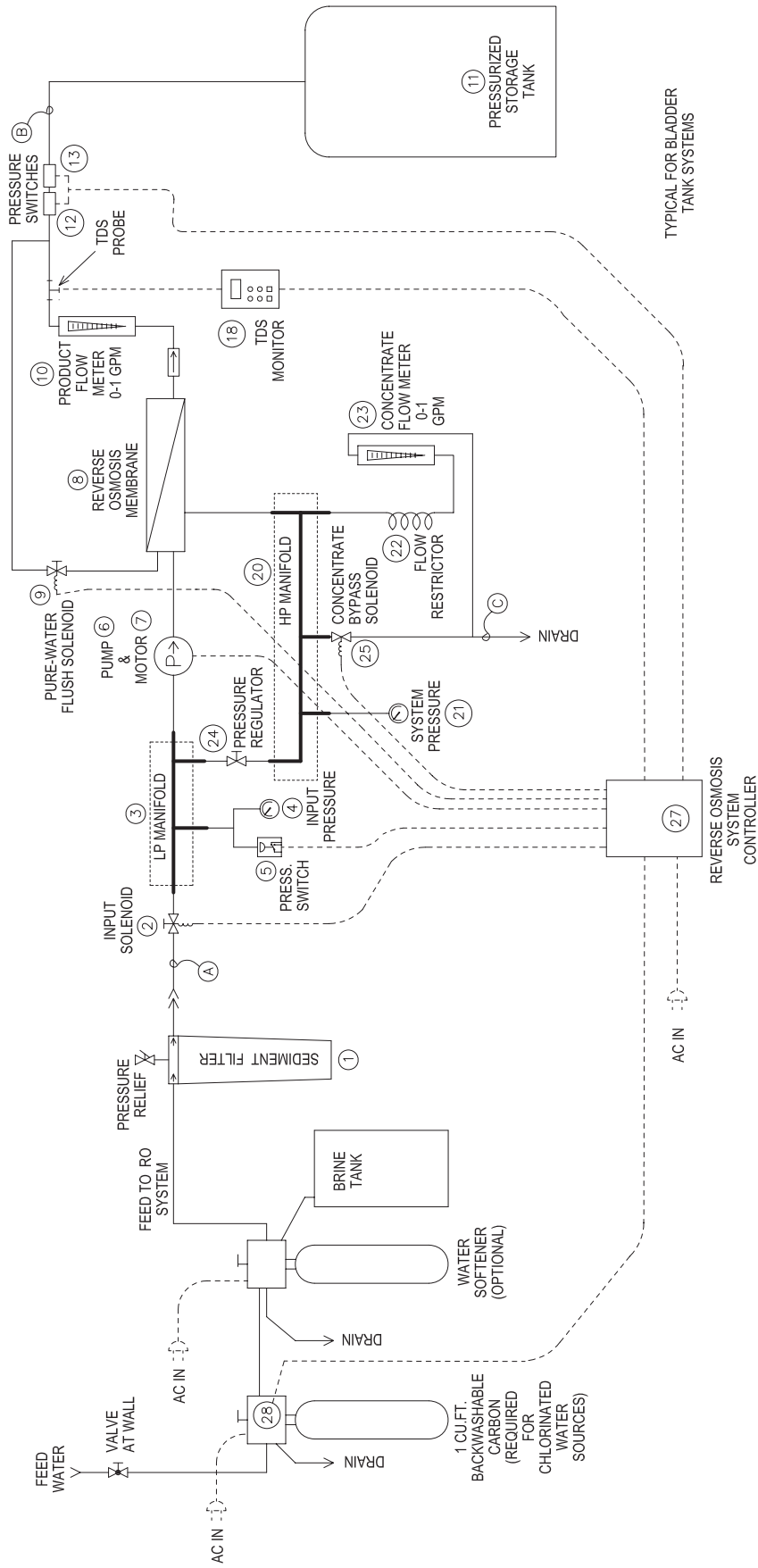

Schematic for All Systems Using Bladder Tank

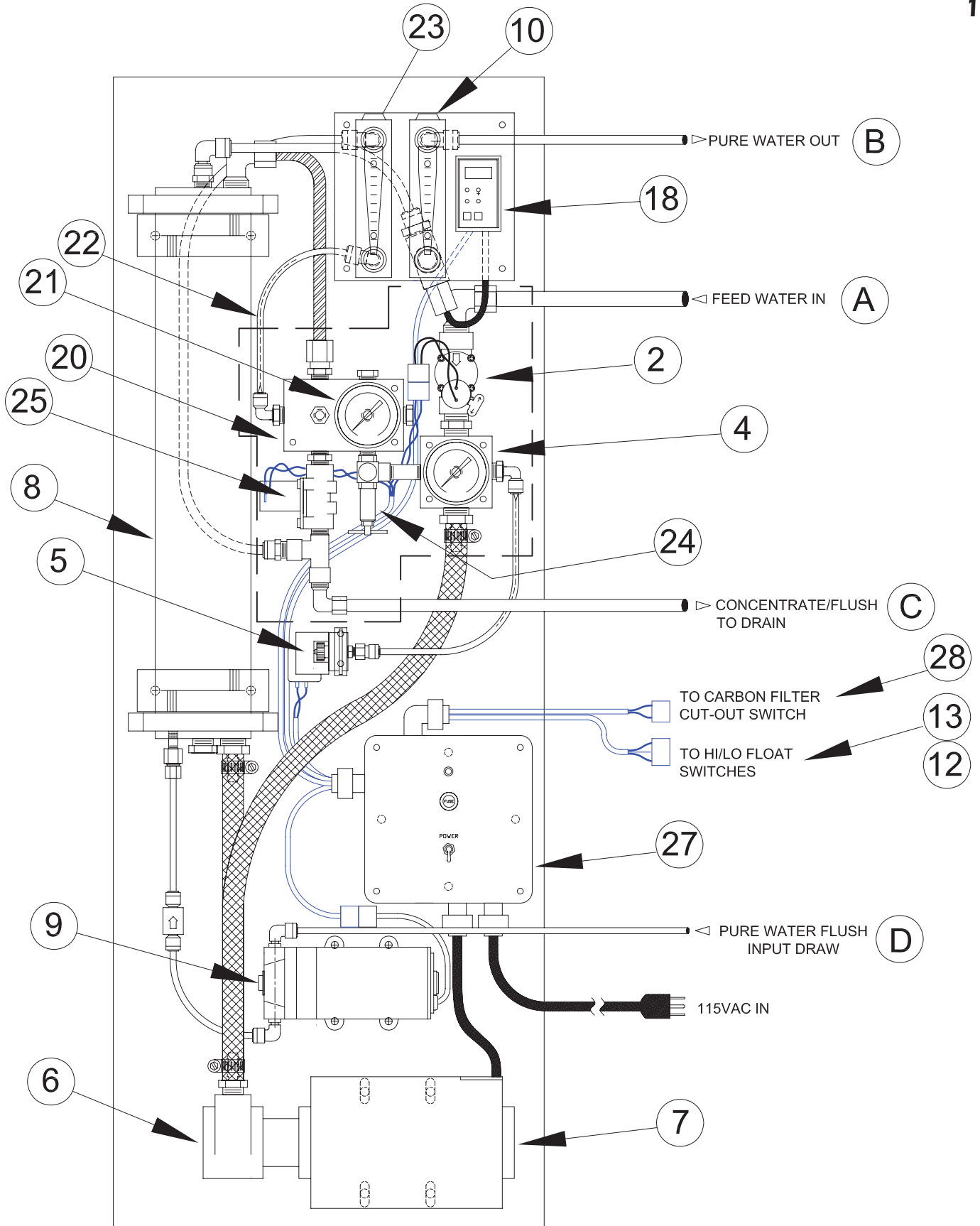

PSP-600, PSP-1000 : Front Side View

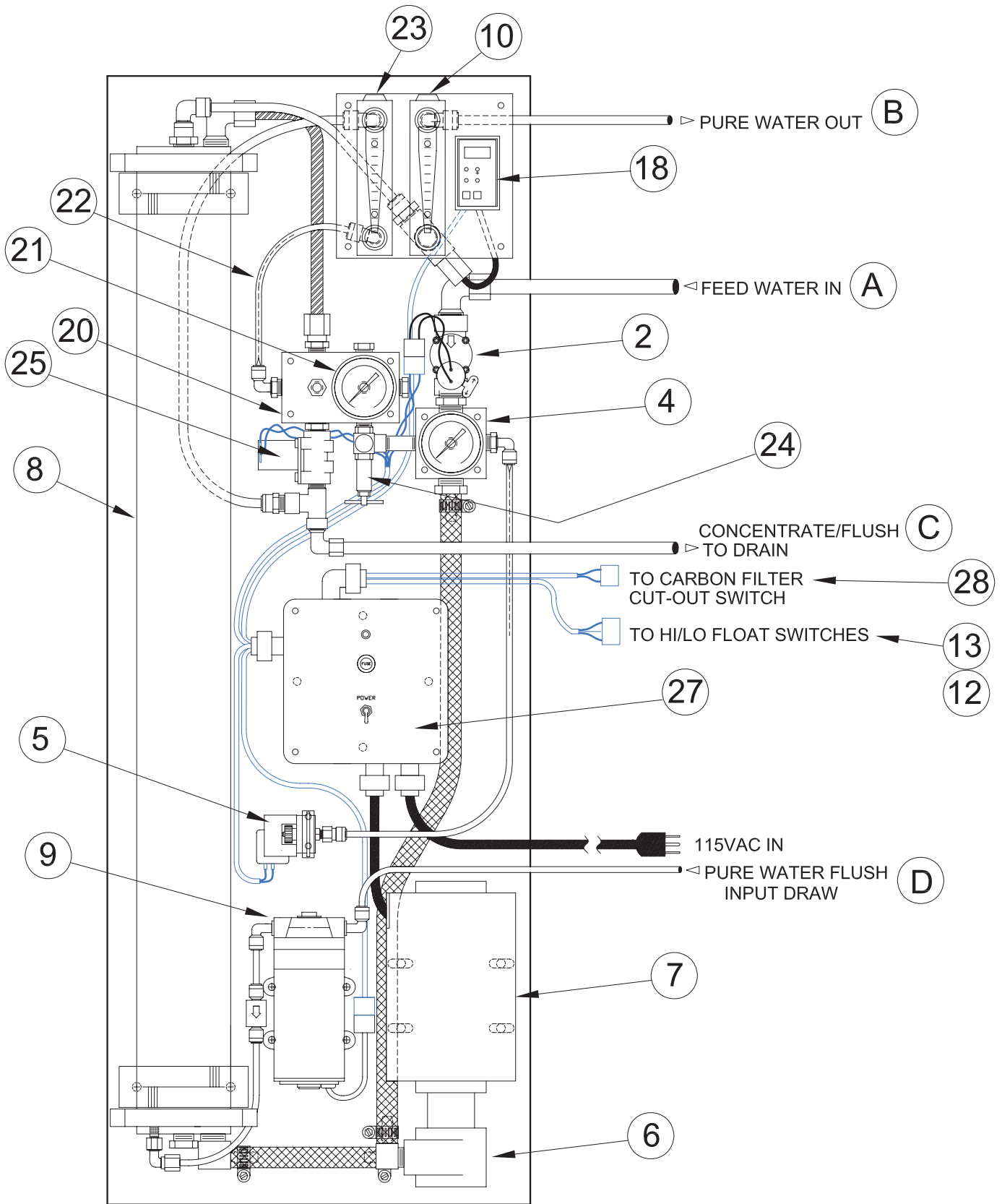

PSP-1600 : Front Side View

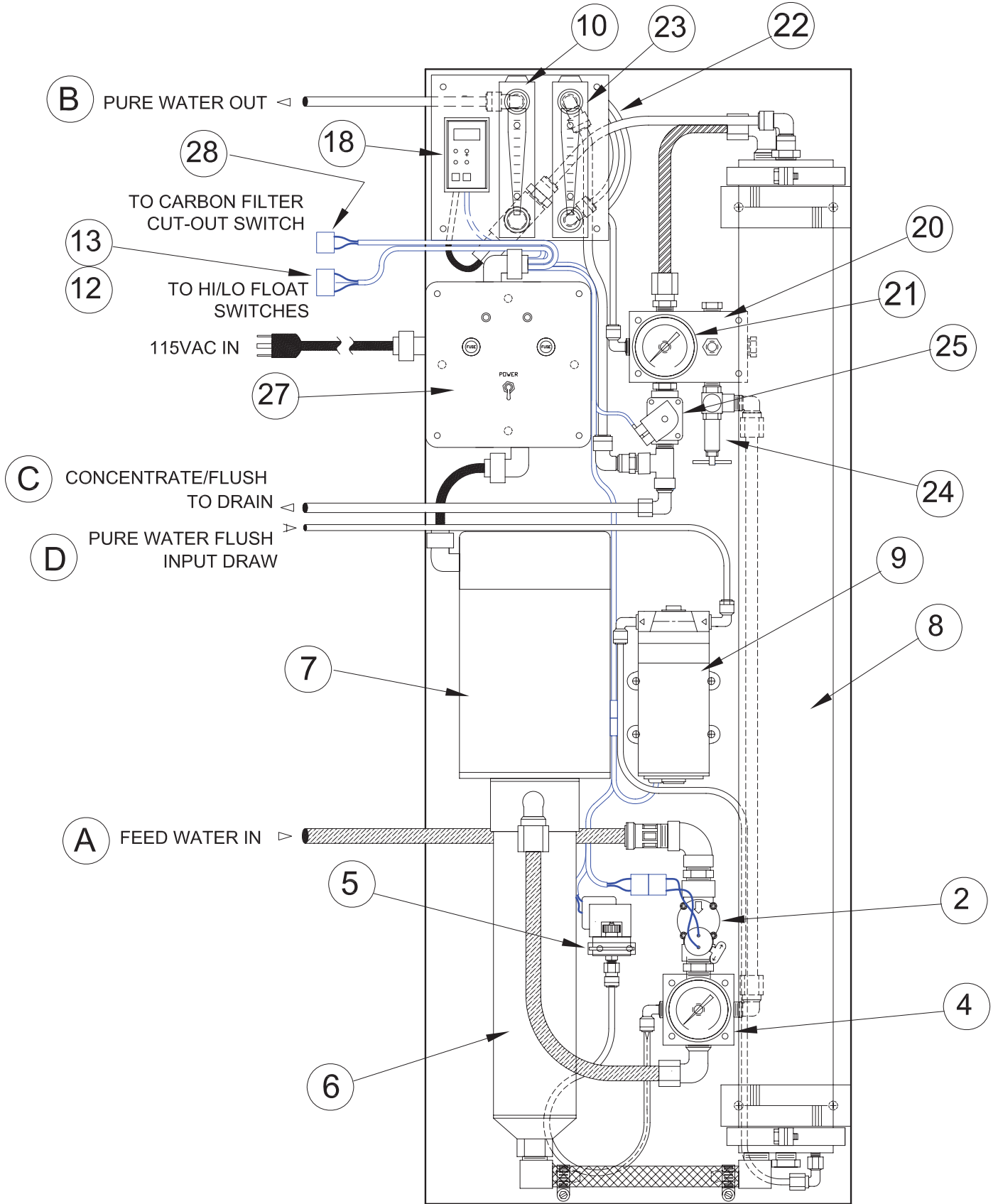

PSP-2700 : Front Side View

Theory of Operation: Electronic Control System

The Reverse Osmosis System Controller (27) is the grey box on the front of the system. Inside this box is a 24 VAC transformer, a power relay, and a microprocessor-based control board. The transformer provides a safe voltage level for all control system functions. On the front of the controller is the main power switch, system fuse (15 amp, slo-blow), and two LEDs. The green LED blinks at a 1 second rate and indicates proper operation of the control board. The red LED indicates error conditions. Currently, error conditions indicated by the blinking red LED include: 1- float switch faults and, 2- low feed water input pressure.

When water is withdrawn from the tank to a point below the low-level float (or pressure switch) (12) and the carbon filter cut-out switch is closed, the input solenoid (2) is activated. When sufficient feed-water input pressure is sensed by the input pressure switch (5), the control board will activate the power relay which in turn will apply power to the main pump (6) and motor (7). The pump / motor will boost the recirculating system pressure to 100-110 psi.

If, at any time during a fill cycle, the input pressure drops enough to de-activate the input pressure switch, the main pump and motor will be powered down. The control board will then attempt two more start sequences. If low input pressure is detected two more times, the system will shut down completely and indicate the condition by the red blinking LED. The controller will need to be powered down and a determination as to the cause of the persistent low pressure condition will have to be made.

A normal fill cycle will terminate when the water reaches the high-level float (or pressure switch) (13). A flush cycle will begin with the input solenoid and main pump continuing to operate while opening the concentrate bypass solenoid (25). The flush cycle will terminate after 45 seconds; the bypass solenoid is turned off and the pump and motor will spin down before the input solenoid is turned off, protecting the pump from a starvation / cavitation condition. For the next six minutes, the pure water flush pump (9) is activated, flooding the membrane with a pure-water bath until the fill cycle starts over again.

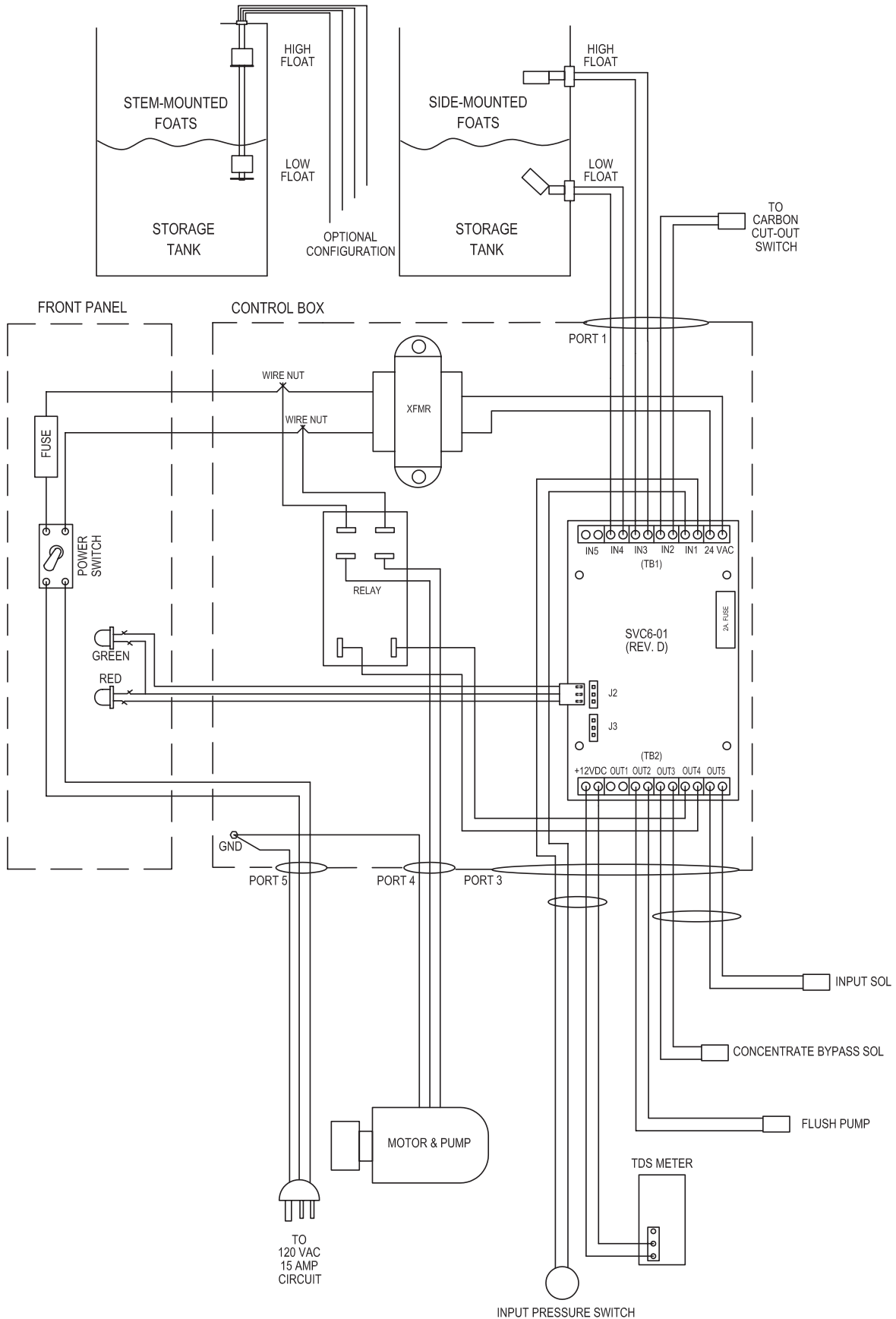

All Systems : Electrical Schematic

The Need for Pre-Treatment:

RO pre-filtration should be a combination of sediment, carbon filtration, and water softening. The sediment filter brings the feed water NTU value to < 1 and the carbon filter further reduces the sediment & turbidity levels in your filters, reducing chlorine, chloramines, and VOC levels in the water down to acceptable levels. Because of the high recovery of the pumped RO systems, we highly recommend the use of a water softener ahead of the reverse osmosis system. This will greatly increase membrane life and reduce maintenance costs of the RO system.

Preventative Maintenance Standards:

To be able to properly service and maintain RO membrane systems, it is important to understand the system history, so the first time a unit is serviced, there should be a system history card filled out and attached to the machine. Knowing what the settings were after the last service will be very helpful in understanding what is required for service in the future.

PM Requirements - Follow the procedures in this manual and,

Quarterly:

- Change all pre-filters and o-rings
- Clean filter housings
- Inspect system for leaks
- Check all system operating pressures
- Check membrane production
- Check membrane water quality
- Record all information in a system history log

Annually:

- In addition to above, sanitize all filter housings with Kay-5 sanitizer (one packet to 2.5 gallons of warm water) or similar product. Follow standard sanitizing procedure, clean with mild detergent, rinse with clear water, fill filter with sanitizer solution, and allow to air dry or reassemble. **Do not rinse the parts after sanitizer solution.**
- Inspect the tank for any algae growth and clean with Kay-5 sanitizer if necessary.

Installation and Setup:

Carbon Filter and Water Softener Installation

Follow Diagram on page 7, 8, or 9 for sequence and hook-up of components of water purification system. Install per accepted plumbing standards and practices.

Important Note: On carbon filter or water softener not equipped with system lock-out controls, never operate RO System during carbon filter backwash or water softener regeneration. System lock out control is not necessary when used only with twin bed water softeners.

Plumbing Connections

1. Carbon Filter & Water Softener feed lines - 1" with bypass
2. Carbon Filter & Water Softener drain lines - 1/2" minimum
3. Feed water line to pre-filter on RO unit - 5/8" minimum.
4. Product water line to store - 1/2" blue tubing.
5. Reject water line to drain - 1/2" yellow tubing, see diagram at right.
Terminate 1" above drain pan. (must be separate from overflow line).
6. Tank overflow line to drain - 3/8" yellow tubing, see diagram at right.
Terminate 1" above drain pan. (must be separate from drain tubing).

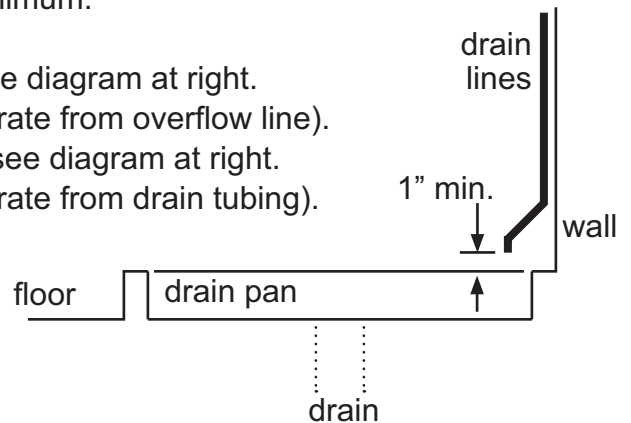

Compression Fittings and Connections

For 1/4", 3/8", 1/2", and 5/8" poly tubing to brass compression fittings:

1. Cut the tubing end squarely and remove internal and external burrs.
2. Remove compression nut from the compression fitting and slide it over the tubing.
3. Slide the white plastic collar over the tubing.
NOTE: Smaller diameters have a tapered collar while larger diameters (5/8") have dual-tapered collars. Tapered collars must slope towards the fitting. See typicals at right.
4. Place the brass insert into the end of the tubing.
5. Firmly insert assembly into fitting until it bottoms out.
6. Tighten nut securely, do not over-tighten.

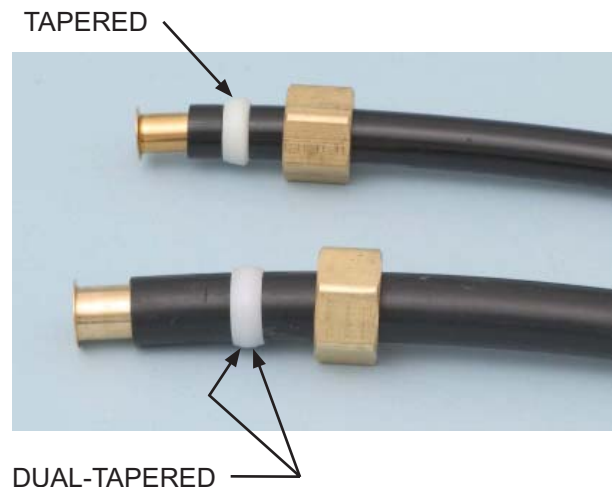

Installation and Setup: (continued)

Water Purification System Start-Up

1. Close shut-off valve ahead of the pre-filter.
2. Set the carbon filter (red handle) by-pass valve to by-pass position.
3. Turn the black manual regeneration knob (rotate clockwise one click from the service position) on the carbon filter control head to the backwash position. Make sure the carbon filter is plugged into a 120V outlet. Now slowly turn the red by-pass valve handle located at the back of the carbon filter to the service position to bleed air from tank. Do not rapidly open this valve. Leave valve partially open until the air has been bled from the tank. Then fully open the valve.
4. Backwash the carbon filter for at least 15 minutes after air has been bled from the tank and until the backwash is clear of black carbon fines.
5. Return the carbon filter control head back to the service position by rotating the black manual backwash knob clockwise around to the service position.
6. Set time of day on the control valve on the carbon filter by depressing the red button and aligning the 24 hour gear to the current time.
7. On the skipper wheel, pull every third tab outward (i.e. #1, 4, 7 and 10). This will backwash the carbon filter every three days.
8. Open the shut-off valve ahead of the pre-filter.
9. With RO system in the OFF position and all plumbing and electrical connections completed, rotate the input solenoid valve lever to manually open the inlet solenoid valve. The word "ON" should be visible.
10. Leave the valve open until air is purged from the system, letting pressure build up to set the low pressure switch.
11. Check feed water connections for any leaks.



Low Pressure Switch shown set at 10 psi and is un-pressurized



Installation and Setup: (continued)

12. Shut the valve by turning lever to close the inlet solenoid valve. The word "OFF" should now be visible.
13. At the control panel, turn the valve to the BYPASS position, open all faucets and rinse the store pipes out for 10 minutes. Close all faucets. Return the control panel valve to RUN.
14. Unplug the Delivery Pump so it will not run.
15. Turn the power switch on the control panel to the "ON" position (UP). This will immediately open the inlet solenoid valve. After 5 seconds, the RO pump will turn on. This motor protection circuitry assures a flooded inlet to the pump prior to pump start-up; eliminating dry starts which could damage the pump.
16. After a few minutes of operation, use a 1/2" wrench to loosen the nut on the threaded shaft of the pressure relief valve, located beneath the high pressure manifold.
17. Adjust the pressure relief valve to 100 psi by turning the brass handle. Rotate clockwise, when viewed from the bottom, to increase the pressure and counter-clockwise to decrease the pressure.
18. When adjusted to the proper pressure, lock the nut back in place.
19. Check the product water to waste water ratio. It should be approx. 1:1. Note: If not, contact the factory (the flow restrictor may require adjustment).
20. Disconnect the line at the top of the Product Flow Meter. Disconnect the drain line leaving the Tank Overflow Filter and temporarily re-connect it to the Product Flow Meter.
21. Turn the switch on the Control Box to the up, or ON position.
22. Flush the new Mineral Additive Cartridge for 10 minutes.
23. Turn the switch on the Control Box to the down, or OFF position.
24. Disconnect the temporary drain line at the top of the Product Flow Meter. Re-connect the drain line to the Tank Overflow Filter and re-connect the blue line (from the tank) to the Product Flow Meter.
25. Re-connect the Delivery Pump power cord.
26. Check for leaks and carefully tighten any compression fittings if necessary.

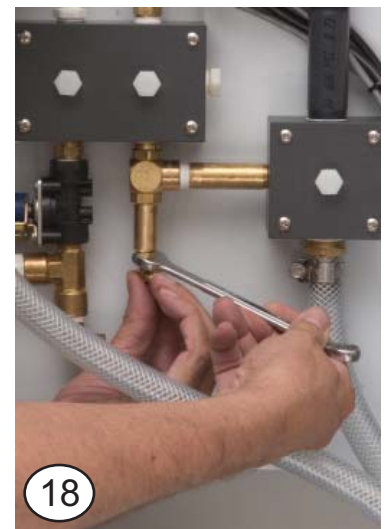
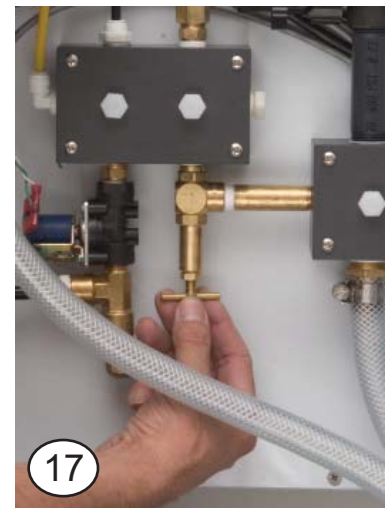

Troubleshooting Guide:

This guide is to assist you in identifying the most common operating problems you may experience with your water purification system.

PROBLEM	PROBABLE CAUSE	CORRECTIVE ACTION
Low system inlet pressure.	Insufficient feed water pressure or flow	Check feed pressure, open feedwater valve, check for restrictions.
	Clogged pre-filter	Replace pre-filter cartridge.
	Closed valve ahead of RO System	Check for closed valves.
Low system operating pressure.	Pump not operating correctly	Repair or Replace pump.
	Defective pressure regulator valve	Replace or repair valve.
Low permeate flow rate	Low operating pressure	See above possible causes for low operating pressure.
	Dirty or fouled membrane	Replace it.
	Operating on cold water	If possible operate with a feedwater temperature of 72-80 °F (22-27 °C).
Excessive Permeate flow rate.	Defective product water membrane O-rings.	Check product water tube O-rings and replace if necessary.
	Damaged membrane (possibly due to chlorine damage)	Replace membrane.
	Ruptured membrane	Replace membrane.
Water flowing when system is turned off	Inlet solenoid valve not closing or seating properly	Clean valve or replace.
RO System cycles ON and OFF.	Insufficient system inlet pressure	See above possible causes for low system inlet pressure.

Troubleshooting Guide: (continued)

PROBLEM	PROBABLE CAUSE	CORRECTIVE ACTION
High product water conductivity (declining rejection)	Dirty or fouled membranes	Replace membrane.
	Product water tube O-ring seal broken or damaged	Replace O-ring, check sealing surfaces on O-ring groove, interconnectors and end caps. Replace damaged parts.
Power switch on, tank water level below the low float, unit not operating	Membrane put in backwards	Install membrane correctly.
	Float switch has cut power to machine	Check position of float in the storage tank.
	Defective Float	Replace Float.
	Thermal overload in motor	Allow motor to cool and re-start system. Check amp draw of motor.
	No power to system	Check fuses or circuit breakers, measure voltage.
	Motor and/or pump not operating properly	Repair or Replace pump/motor.
	Micro-switch on either carbon filter or water softener not functioning properly	Replace micro-switch.
Carbon filter or water softener control valve not in service position	Set the control valves to the service position.	
Low system inlet pressure	See previous page for possible causes for low system inlet pressure.	